



OMPAR srl
via A. Rossi, 26
36057 Arcugnano (VI) - ITALY
T +39 0444 240545
F +39 0444 240521
ompar@ompar.com
ompar.com

OVER **50**
YEARS OF
PRECISION



DVP S16

C.N.C. PATENTED DIAMOND CUTTING MACHINE FOR MICROCAST SPHERICAL ELEMENTS

Diamond cutting machine mod. DVP S16 with 12 axes computerised numerical control suitable for diamond cutting microcast spherical elements on beads.

DIAMANTATRICE C.N.C. BREVETTATA PER ELEMENTI SFERICI MICROFUSI

Diamantatrice mod. DVP S16 a controllo numerico computerizzato a 12 assi adatta per diamantare elementi sferici microfusi.

MACHINABLE PRODUCTS

Beads

Max. dimensions beads	Ø28 x 45 mm
Number of working axes	12
Axis tilt Table	-65° / +65°
Axis tilt Tool Heads	-45° / +180°

VERTICAL HEAD

Tool rotation speed	from 0 to 20000 rpm
Tool pincer diameter	6 mm

HORIZONTAL HEAD

Tool rotation speed	from 0 to 15000 rpm
Tool diameter	80 mm

INSTALLATION DATA

Wattage	4.8 kW
Power supply	230 V, 50/60 Hz, 1~
Pneumatic supply	6 bar
Weight	700 kg

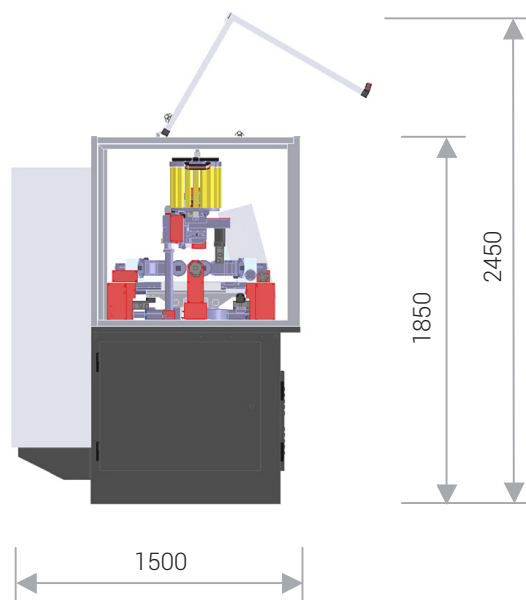
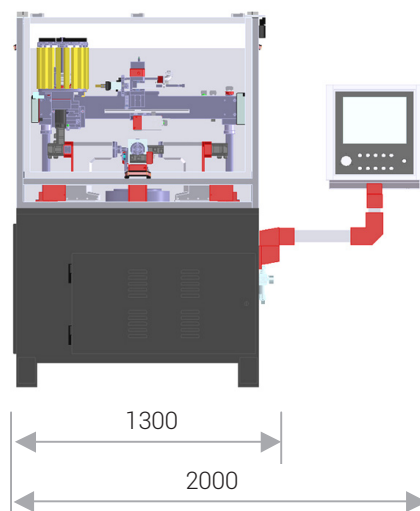

DVP S16